



The battery is manufactured with porous rubber and rubber separator and transparent AS case. The tubular positive plate, pasted negative plate and acid-proof bolt is applied. The combination plugs may be applied for maintenance-free for over 5 years.

Performance Characteristics

- **Nominal Voltage** 2V
- **Number of Cell** 1
- **Nominal Capacity (77°F / 25°C)**
 - 240 Hour rate (9.1A, 1.85V) 2196Ah
 - 100 Hour rate (18.0A, 1.85V)..... 1800Ah
 - 10 Hour rate (150A, 1.80V) 1500Ah
 - 5 Hour rate (252A, 1.80V) 1260Ah
 - 3 Hour rate (375A, 1.75V) 1125Ah
 - 1 Hour rate (795A, 1.67V) 795Ah
- **Operating Temperature Range**
 - Discharge -20 ~ 65°C
 - Charge -10 ~ 65°C
 - Store -20 ~ 65°C
- **Self-Discharge 68°F (20°C)**
 - Capacity declined per 28 days..... 4.5%
- **Max. discharge current 77°F / 25°C** 7500A(5S)

General Features

- **The battery has a long service life, under float charging, ambient temperature 25C, it can operate over 20 years.**
- **Maximum cycle stability and durability.**
- **The battery meet the standard specified in IEC896-1 and DIN40736.**
- **High Quality and reliability.**
- **Water supplement cycle 0.25 - 1 year (normal)**
- **1-2 year (choose water content recombination valve)**
- **High cycle service life**
- **Better temperature resistance performance**
- **Excellent deep cycle performance**
- **Superior low current discharge performance**
- **Better charge reception capability**
- **Better safety performance and reliability**
- **Modular and personified installation design**
- **Performance price ratio is high and yearly operating cost is low**
- **Eco-friendly, cycle application**

Charging Method

Application		Initial Charge	Equalizing Charge	Float Charge
Charging Method		Constant Current Charging	Constant Current Charging	Constant Current Charging
Charging Voltage at 20°C		----	2.38 ~ 2.42V	2.23 ~ 2.27V
Temperature Compensation Coefficient of Charging Voltage		----	-3 mV/°C	-3 mV/°C
Charging Current		75A	150A (Max. Current)	150A (Max. Current)
Charging Time 20°C	100% Discharge	60h	60h	36h
	50% Discharge	48h	48h	24h
Temperature		0 ~ 45°C (32 ~ 113 °F)		

Main Applications

- **DC power and standby power for operate equipment of power system and nuclear power station**
- **Standby power supply for various communication and signal systems**
- **Solar energy, wind energy, hydroelectric generation power storage and wind & solar hybrid project**
- **Standby power supply for shipping**
- **Standby power supply for petrochemical industry**
- **Standby power supply for UPS, medical facilities and emergency lightings and so on**
- **UPS**



Structure Features

Plate

Positive plate adopts tubular type plate which can effectively prevent active substance falling, positive plate frame is made of complex alloy, the alloy crystal particle is tiny and dens. The corrosion-resisting performance is good and service life is long. The negative plate adopts pasted plate, grid adopts radiated structure, which enhances utilization ratio of active substance and discharge capability of strong current; moreover, the charge reception capability is strong.

Battery Case

Adopts AS transparent case with corrosion prevention, high strength and beautiful appearance, the internal structure and state of battery can be directly observed via transparent case.

Separator

The combined separator of multi-hole corrugated plastic and micro-bore rubber separator have bigger electrolyte storage space, which enhances dispersion speed of electrolyte, greatly reduces internal resistance of battery and prevents dendrite short circuit after deep discharge.

Terminal Sealing

The built-in copper-core lead-based terminal post has strong current capacity and corrosion resistance. The unique terminal post sealing structure can effectively eliminate the stress which is generated due to plate extension, leaking is avoided, sealing reliability of terminal post is ensured and service life of battery is greatly increased.

Acid Resistant Bolt

Adopt special funnel-shaped acid resistant bolt which can filter acid fume and prevent flame, the density and temperature of electrolyte can be measured directly, use is safe and maintenance is convenient.

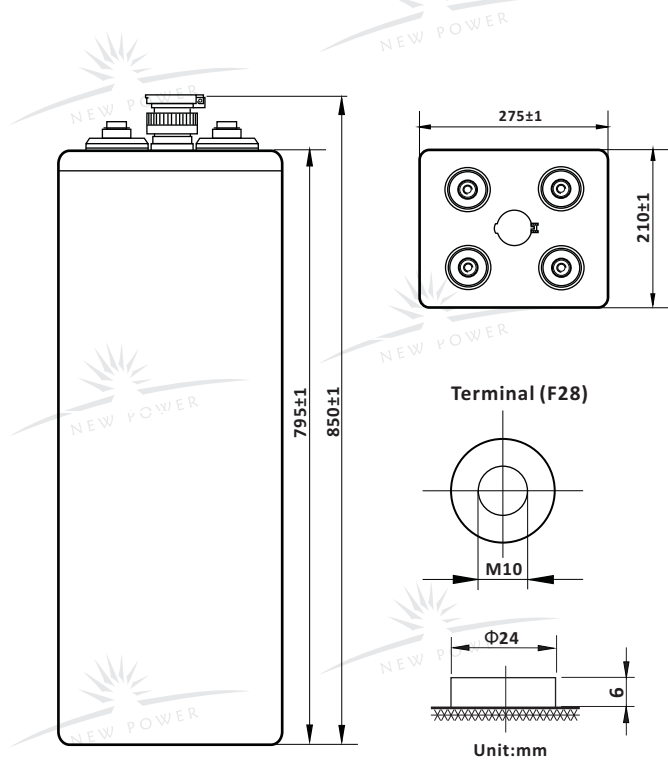

Dimensions and Weight

Type	Length	Width	Height	Total Height	Dry Weight	Wet Weight	Acid Weight (d1.24)
SI Units	275mm	210mm	795mm	850mm	75Kg	105Kg	30Kg
English Units	10.8inch	8.27inch	31.3inch	33.5inch	165.35lbs	231.5lbs	66.1lbs

Constant Current Discharge (Amperes at 77°F/25°C)

V/cell	30min	1h	2h	3h	4h	5h	6h	8h	10h	24h	48h	100h	120h	240h
1.70V	974	746	495	383	308	261	228	183	153	----	----	----	----	----
1.75V	897	705	480	375	305	255	225	180	153	79.5	43.5	----	----	----
1.80V	833	660	465	356	300	252	218	177	150	78.0	43.5	----	----	----
1.85V	758	648	435	348	285	237	210	173	146	76.5	42.0	18.0	15.6	9.10
1.90V	739	608	390	330	266	230	203	165	140	72.0	40.5	17.7	15.3	9.00

Constant Power Discharge (Watts at 77°F/25°C)

V/cell	30min	1h	2h	3h	4h	5h	6h	8h	10h	24h	48h	100h	120h	240h
1.70V	1764	1389	920	714	575	489	437	353	296	----	----	----	----	----
1.75V	1632	1316	897	704	572	482	432	347	296	159	87.0	----	----	----
1.80V	1566	1235	875	669	567	477	422	345	294	156	87.8	----	----	----
1.85V	1442	1221	824	662	545	456	413	341	288	153	84.8	36.6	31.8	18.8
1.90V	1397	1161	750	635	513	446	402	329	279	145	82.5	36.0	31.4	18.5

