



AGM BATTERY NH Series

NH12-380W



The rechargeable batteries are lead-lead dioxide systems. The dilute sulfuric acid electrolyte is absorbed by separators and plates and thus immobilized. Should the battery be accidentally overcharged producing hydrogen and oxygen, special one-way valves allow the gases to escape thus avoiding excessive pressure build-up. Otherwise, the battery is completely sealed and is, therefore, maintenance-free, leak proof and usable in any position.

Battery Construction

COMPONENT	POSITIVE PLATE	NEGATIVE PLATE	CONTAINER	COVER	SAFETY VALVE	TERMINAL	SEPARATOR	ELECTROLYTE
Raw material	Lead dioxide	Lead	ABS	ABS	Rubber	Copper/Plug	Fiberglass	Sulfuric acid

Performance Characteristics

- **Nominal Voltage** 12V
- **Number of Cell** 6
- **Nominal Capacity (77°F/25°C)**
 - 15 min Wattage @ 1.67V 380W/cell
 - 10 Hour rate (9A, 10.8V) 98Ah
- **Internal Resistance**
 - Fully charged battery (68°F/20°C) 4.8mΩ
- **Self-Discharge 68°F (20°C)**
 - Capacity declined per month 3%
- **Max. discharge current 68°F/20°C** 1000A(5S)
- **Short Circuit Current** 2100A
- **Charge Methods: constant voltage charge 68°F/20°C**
 - Cycle use 14.4 ~ 14.7V
 - Max. Current 25A
 - Standby use 13.6 ~ 13.8V

General Features

- **Absorbent Glass Mat (AGM) technology for efficient gas recombination of up to 99% and freedom from electrolyte maintenance or water adding.**
- **Not restricted for air transport-complies with IATA/ICAO Special Provision A67.**
- **A recognized component of CE and UL**
- **Computer designed lead, calcium tin alloy grid for high power density.**
- **Long service life, float or cyclic applications.**
- **Maintenance-free operation.**
- **Low self discharge**
- **Design life 10 years**

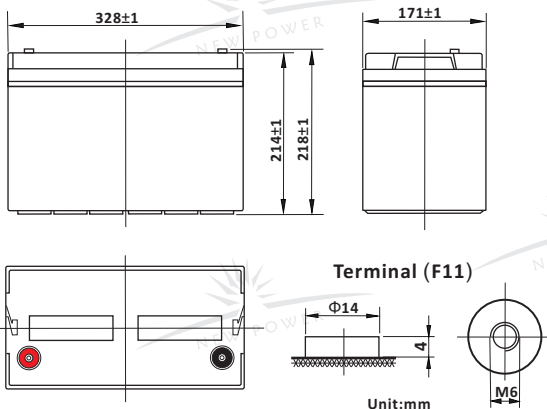

Constant Current Discharge (Amperes at 77°F/25°C)

V/cell	10min	15min	30min	45min	1h	3h	5h	10h	20h
1.60	283.0	220.0	125.0	91.0	75.0	29.1	19.5	10.3	5.45
1.65	270.0	210.0	122.0	88.5	73.5	28.6	19.1	10.2	5.40
1.70	255.0	198.0	118.0	86.0	72.0	28.0	18.7	10.1	5.35
1.75	240.0	186.0	114.0	83.5	70.5	27.4	18.3	10.0	5.30
1.80	223.0	173.0	109.0	80.5	68.8	26.8	17.8	9.80	5.20

Constant Power Discharge (Watts at 77°F/25°C)

V/cell	10min	15min	30min	45min	1h	3h	5h	10h	12h
1.60	471.0	388.0	231.0	168.0	128.0	52.3	35.5	20.6	17.2
1.65	455.0	383.0	223.0	162.0	126.0	51.4	34.8	20.4	17.1
1.67	445.0	380.0	220.0	160.0	125.0	51.0	34.5	20.3	17.0
1.70	432.0	370.0	215.0	157.0	123.0	50.5	34.1	20.2	16.9
1.75	424.0	358.0	207.0	152.0	120.0	49.6	33.4	20.0	16.8
1.80	396.0	342.0	197.0	145.0	116.0	48.5	32.7	19.7	16.5

Dimensions and Weight

Type	Length	Width	Height	Total Height	Approx. Weight
SI Units	328mm	171mm	214mm	218mm	31Kg
English Units	12.91inch	6.73inch	8.43inch	8.58inch	68.3lbs

(Note: The above characteristics data are average values obtained within three charge/discharge cycles not the minimum values.)



