



# GOLF CART BATTERY EV Series



**EV6-185**

The rechargeable batteries are lead-lead dioxide systems. The dilute sulfuric acid electrolyte is absorbed by separators and plates and thus immobilized. Should the battery be accidentally overcharged producing hydrogen and oxygen, special one-way valves allow the gases to escape thus avoiding excessive pressure build-up. Otherwise, the battery is completely sealed and is, therefore, maintenance-free, leak proof and usable in any position.

## Battery Construction

COMPONENT	POSITIVE PLATE	NEGATIVE PLATE	CONTAINER	COVER	SAFETY VALVE	TERMINAL	SEPARATOR	ELECTROLYTE
Raw material	Lead dioxide	Lead	ABS	ABS	Rubber	Copper	Fiberglass	Sulfuric acid

## Performance Characteristics

- **Nominal Voltage** ..... 6V
- **Ampere Hour Capacity**
  - 20 Hours rate (10A, 5.4V) ..... 200Ah
  - 10 Hours rate (18.5A, 5.4V) ..... 185Ah
  - 5 Hours rate (31.8A, 5.25V) ..... 159Ah
  - 3 Hours rate (48.0A, 5.1V) ..... 144Ah
  - 1 Hour rate (117A, 5.1V) ..... 117Ah
- **Minutes of Discharge**
  - 25A to 5.25V ..... 366
  - 75A to 5.1V ..... 89
  - 100A to 5.1V ..... 63
  - 56A to 5.1V ..... 124
  - 85A to 5.1V ..... 78
- **Cranking Amps**
  - 32°F/0°C ..... 650
  - 0°F/-18°C ..... 500
- **Internal Resistance**
  - Fully charged battery (77°F/25°C) ..... 2.0mΩ
- **Self-Discharge (68°F/20°C)**
  - Capacity declined per month ..... 3%
- **Opening temperature Range**
  - Discharge ..... -20 ~ 60°C
  - Charge ..... -10 ~ 50°C
  - Storage ..... -20 ~ 60°C
- **Max. discharge current (77°F/25°C)** ..... 1000A(5S)
- **Short Circuit Current** ..... 2775A
- **Charge Methods: constant voltage charge (77°F/25°C)**
  - Cycle use ..... 7.35 ~ 7.45V
  - Max. Current ..... 37.0A
  - Standby use ..... 6.80 ~ 6.90V

## General Features

- **Environmental friendly**
- **α-DC technology**
- **Computer-aided 99.99% pure heavy-duty lead calcium grid design**
- **Anchored plate groups to guard against vibration**
- **Tank formed plates for evenly formed and capacity matched plates**
- **Wide operating temperatures (-40° to 60°)**
- **Industry leading size and performance options**
- **Double insulating Micro porous glass fiber separators**
- **Flame arresting pressure regulated safety sealing valves for safety**
- **Low self discharge rates (1-3%/month)**
- **Multi-terminal options**
- **Removable carry handles**
- **Classified as "Non-Spillable Battery" for transport**
- **Complies with DOT HMR49, Non-Hazardous Material**
- **Design Life 10 years**

## Application Field

- **Golf and Electric Vehicles**
- **Floor Machines**
- **Aerial Lifts and Fork Lifts**
- **Solar and Renewable Energy**
- **Marine and RV**
- **Broadband and Cable TV**
- **Mobility and Medical**
- **Equipment Wheelchair**
- **Telecommunications**
- **Uninterruptible Power Supply**

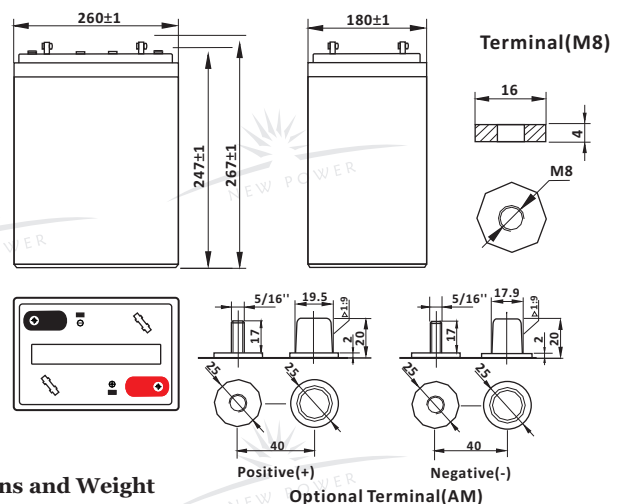

## Dimensions and Weight

Type	Length	Width	Height	Total Height	Approx. Weight
<b>SI Units</b>	260mm	180mm	247mm	267mm	28Kg
<b>English Units</b>	10.2inch	7.1inch	9.7inch	10.5inch	61.75lbs



