



The rechargeable batteries are lead-lead dioxide systems. The dilute sulfuric acid electrolyte is absorbed by separators and plates and thus immobilized. Should the battery be accidentally overcharged producing hydrogen and oxygen, special one-way valves allow the gases to escape thus avoiding excessive pressure build-up. Otherwise, the battery is completely sealed and is, therefore, maintenance-free, leak proof and usable in any position.

Battery Construction

COMPONENT	POSITIVE PLATE	NEGATIVE PLATE	CONTAINER	COVER	SAFETY VALVE	TERMINAL	SEPARATOR	ELECTROLYTE
Raw material	Lead dioxide	Lead	ABS	ABS	Rubber	Copper	Fiberglass	Sulfuric acid

Performance Characteristics

- **Nominal Voltage** 12V
- **Ampere Hour Capacity**
 - 20 Hours rate (5.4A, 10.8V)..... 108Ah
 - 10 Hours rate (10.0A, 10.8V)..... 100Ah
 - 5 Hours rate (17.2A, 10.5V)..... 86Ah
 - 3 Hours rate (26.0A, 10.2V)..... 78Ah
 - 1 Hour rate (63.0A, 10.2V)..... 63Ah
- **Minutes of Discharge**
 - 25A to 10.2V..... 198
 - 75A to 9.6V 48
 - 100A to 9.6V..... 34
 - 56A to 10.2V..... 67
 - 85A to 9.6V..... 42
- **Cranking Amps**
 - 32°F/0°C 650
 - 0°F/-18°C 500
- **Internal Resistance**
 - Fully charged battery (77°F /25°C)..... 3.9mΩ
- **Self-Discharge (68°F /20°C)**
 - Capacity declined per month 3%
- **Opening temperature Range**
 - Discharge..... -20 ~ 60°C
 - Charge..... -10 ~ 50°C
 - Storage..... -20 ~ 60°C
- **Max. discharge current (77°F /25°C)**..... 1000A(5S)
- **Short Circuit Current**..... 1500A
- **Charge Methods: constant voltage charge (77°F /25°C)**
 - Cycle use..... 14.7 ~ 14.9V
 - Max. Current 20.0A
 - Standby use..... 13.6 ~ 13.8V

General Features

- **Environmental friendly**
- **α-DC technology**
- **Computer-aided 99.99% pure heavy-duty lead calcium grid design**
- **Anchored plate groups to guard against vibration**
- **Tank formed plates for evenly formed and capacity matched plates**
- **Wide operating temperatures (-40° to 60°)**
- **Industry leading size and performance options**
- **Double insulating Micro porous glass fiber separators**
- **Flame arresting pressure regulated safety sealing valves for safety**
- **Low self discharge rates (1-3%/month)**
- **Multi-terminal options**
- **Removable carry handles**
- **Classified as "Non-Spillable Battery" for transport**
- **Complies with DOT HMR49, Non-Hazardous Material**
- **Design Life 10 years**

Application Field

- **Golf and Electric Vehicles**
- **Floor Machines**
- **Aerial Lifts and Fork Lifts**
- **Solar and Renewable Energy**
- **Marine and RV**
- **Broadband and Cable TV**
- **Mobility and Medical**
- **Equipment Wheelchair**
- **Telecommunications**
- **Uninterruptible Power Supply**

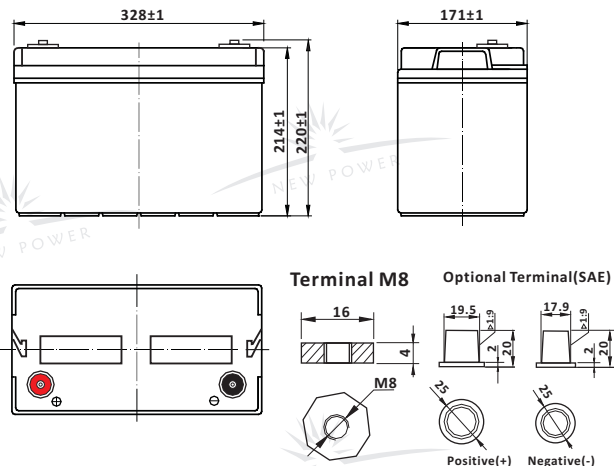

Dimensions and Weight

Type	Length	Width	Height	Total Height	Approx. Weight
SI Units	328mm	171mm	214mm	220mm	30Kg
English Units	12.9inch	6.74inch	8.43inch	8.66inch	66.09lbs

